

Echelon™

CABINETS

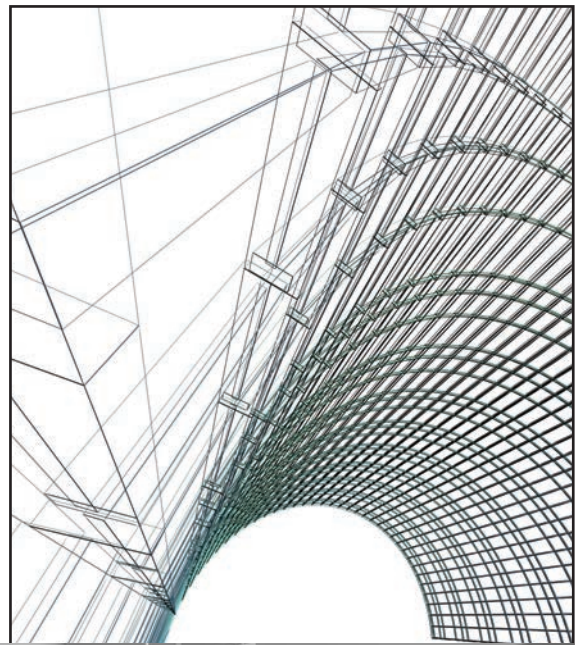

HOW TO MEASURE YOUR KITCHEN

A guide to planning and creating the heart of your home.

1. Measure Your Space

Accurate measurements as indicated in the measuring procedure are the key elements we will need to plan your new kitchen. With this information, our kitchen specialists will be able to help design the kitchen of your dreams!

FLOOR PLAN

Before any planning can start we must know the exact dimensions available to work with. Using the measuring procedure illustrated, carefully prepare a simple floor plan of your existing kitchen.

Your completed floor plan should resemble the diagram shown below. Make sure you show exact locations of doors, windows, hood vents, exhaust, gas line, water line, drains, switches, outlets, light fixtures, and heat vents. Double check all measurements.

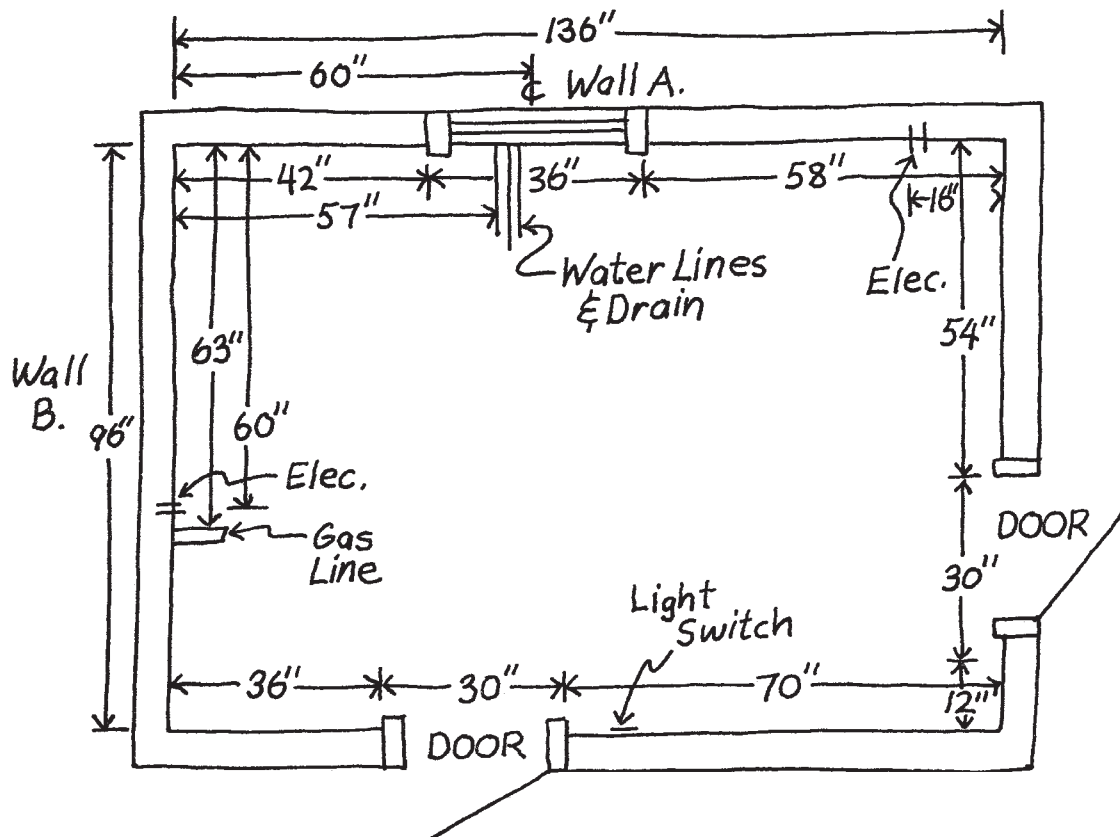

EXAMPLE FLOOR PLAN

MEASURING PROCEDURE

Using a tape measure and graph paper, measure as outlined below:

Horizontal Measurement

1. Measure from wall to wall at 36" height.
2. Measure from corner to window or door opening.
3. Measure across opening from trim edge to trim edge.
4. Measure from edge of trim to far wall. Compare sum of #2, #3, and #4 measurements to step #1.
5. Mark the exact location of water, drain, gas lines and electrical outlets and switches on drawing.
6. Measure from wall to wall above window and compare to #1.

Vertical Measurement

7. Measure from floor to window sill.
8. Measure from window sill to top of window.
9. Measure from top of window to ceiling.
10. Measure from floor to ceiling – Compare to sum of #7, #8, and #9.

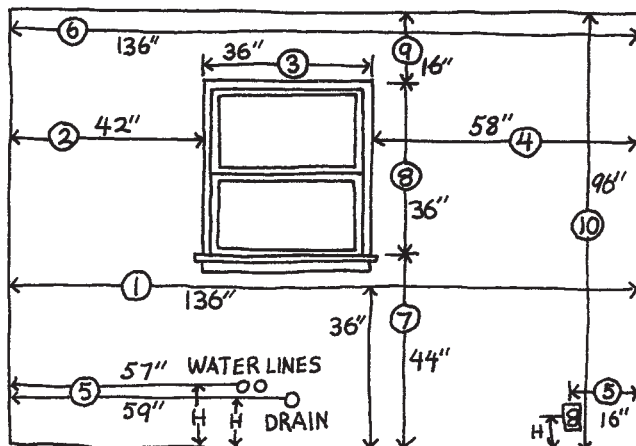

WALL A.

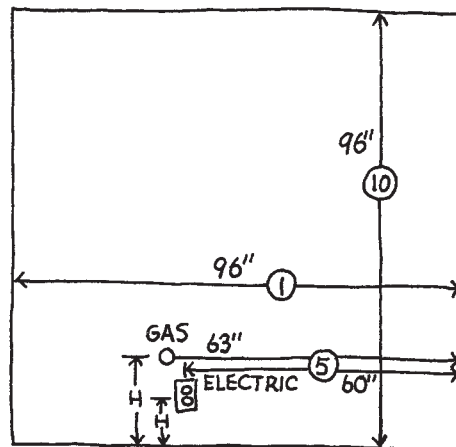

WALL B.

DO-IT-YOURSELF KITCHEN FLOOR PLAN GRID

After all measurements are complete you can begin drawing your kitchen layout using the grid below. Each large square represents 1 square foot and the small squares are 3". Keep your drawing simple like the example floor plan.

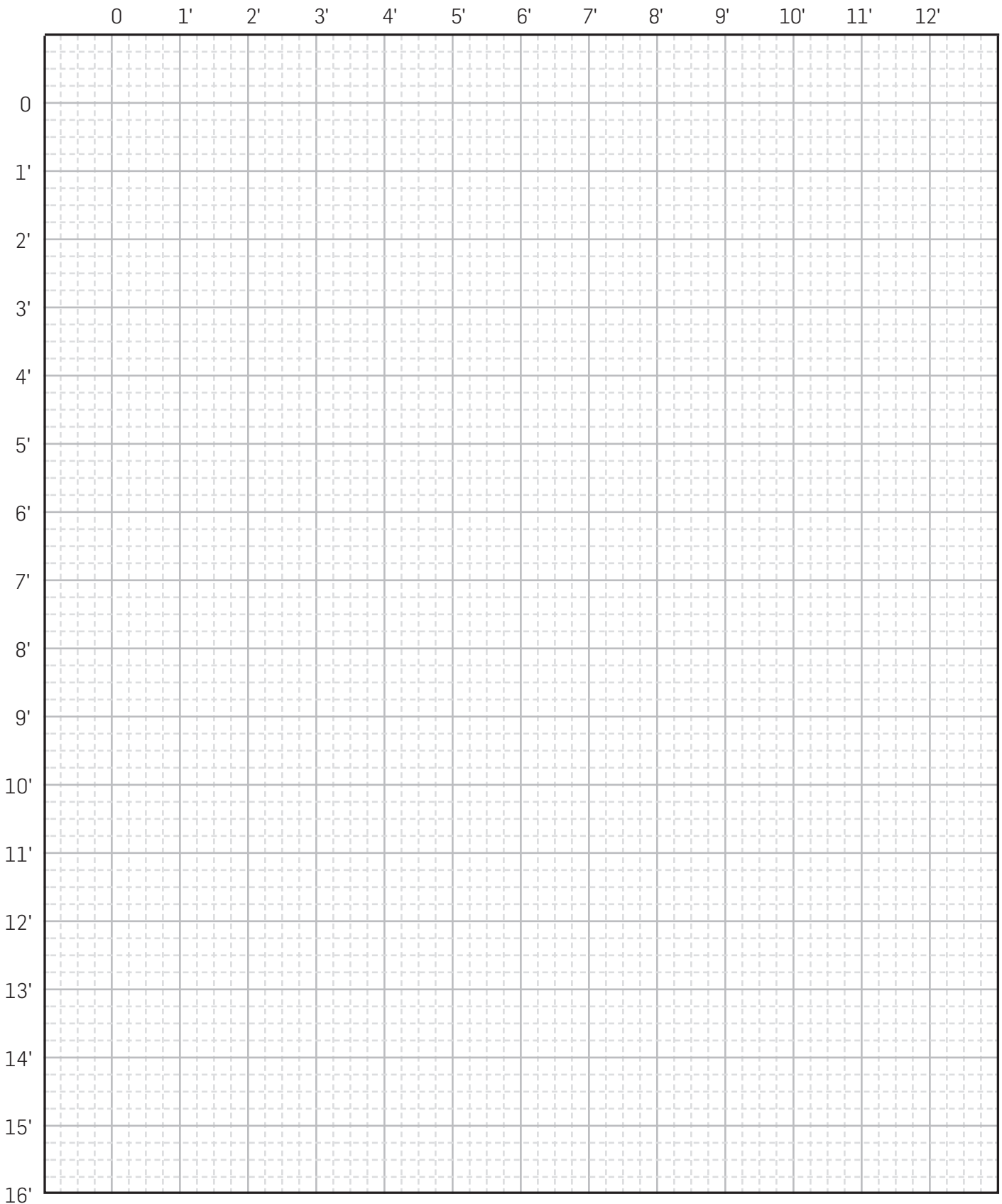

13' 14' 15' 16' 17' 18' 19' 20' 21' 22' 23' 24' 25'

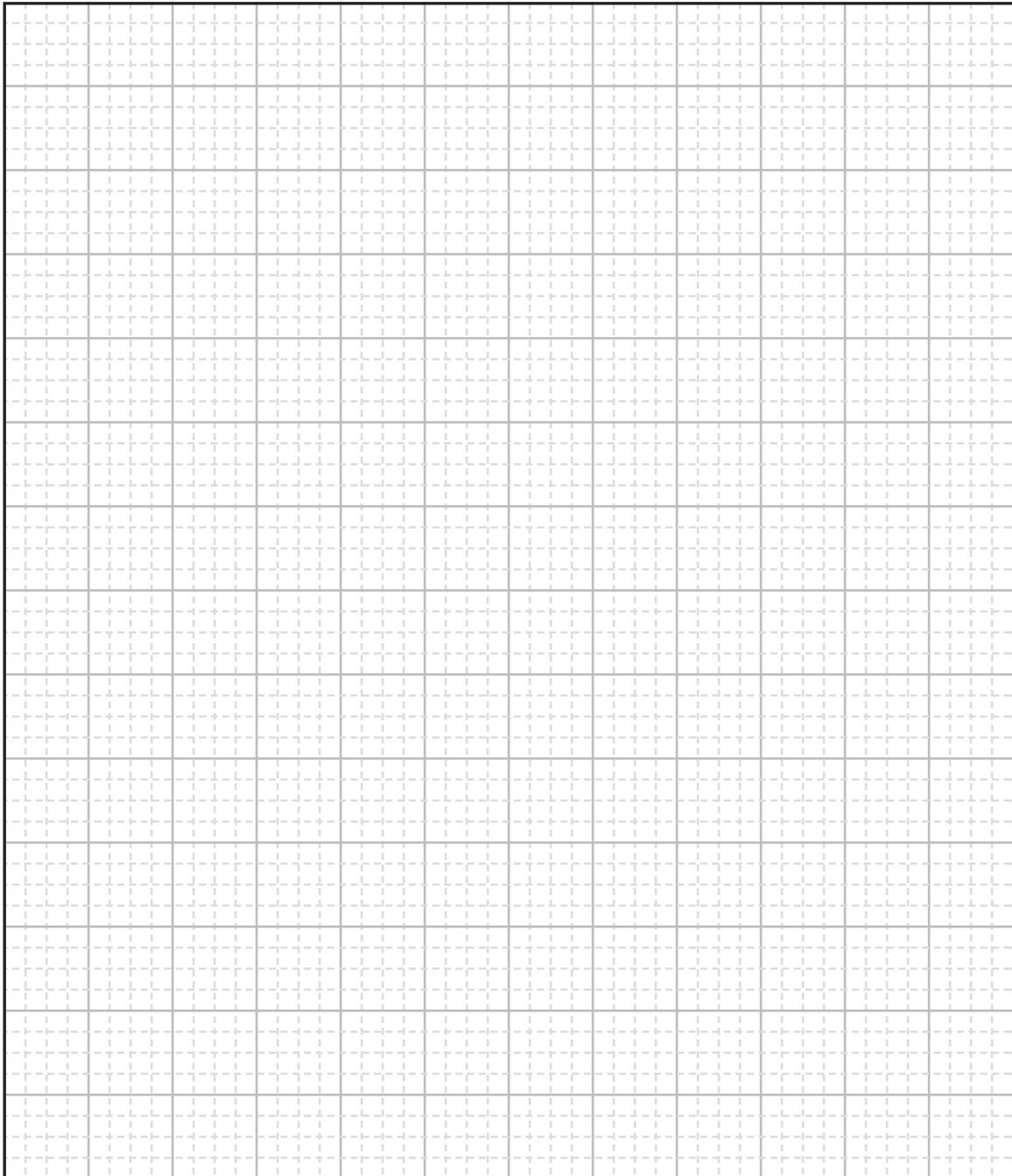

Echelon
CABINERY

Name _____

Address _____

City _____ State _____

Phone _____ Fax _____

2. Appliance/Fixture Information

Show desired locations of appliances on drawing. It is very important to indicate natural gas locations, 220 volt outlets, and any wall mounted telephone (T) or cable TV (CTV) locations.

	Type	Size W x D x H	Hinge Position L/R (Facing Appliance)
Refrigerator			
Range			
Cooktop			
Exhaust Hood			
Wall Oven			
Microwave			
Dishwasher			
Sink			
Disposal			
Compactor			
Freezer			
Other			

AVAILABLE ACCESSORIES

Customize your kitchen with these cabinet accessories and options.

- Mullion Doors/Glass Doors
- Wall Cabinet Decorative Ends
- Wine Rack
- Knick Knack Wall Shelf
- Under Cabinet Organizer
- Stem Glass Holder
- Appliance Garage
- Deluxe Sinkbase Cabinet
- Wood Hoods
- Microwave Wall Cabinet
- Straight Valance
- Curved Valance
- Country Valance
- Base Knick Knack Shelf
- Peninsula Base Knick Knack Shelf
- Base Cabinet Decorative Ends
- Pull-Out Pantry Cabinet
- Fluted Fillers
- Open Shelved Bookcases
- File Drawer Base Cabinet for Desk
- Knee Drawer Cabinet for Desk
- Cutting Board
- Tray Divider
- Spice Trays
- Tiered Cutlery Divider
- Utility Trays
- Cutlery Divider
- Lazy Susan in Wall Corner Cabinet
- Lazy Susan in Base Corner Cabinet
- Sink Front Tilt-Out Trays
- Behind Door Storage Trays
- Waste Baskets
- Door Mounted Spice Racks
- Bread Lid Kit
- Pull-Out Rattan Baskets
- Grocery Bag Holder
- Pull-Out Towel Bar
- Sink Floor Drip Tray
- Deluxe Soft-Close Shelf Trays

3. Design By Computer

After you have completed your kitchen layout drawing, bring it to our showroom. Here the drawing will be discussed and any possible changes can be made. A computerized 3-dimensional layout will be presented. This will give you a realistic rendering of your dream kitchen!

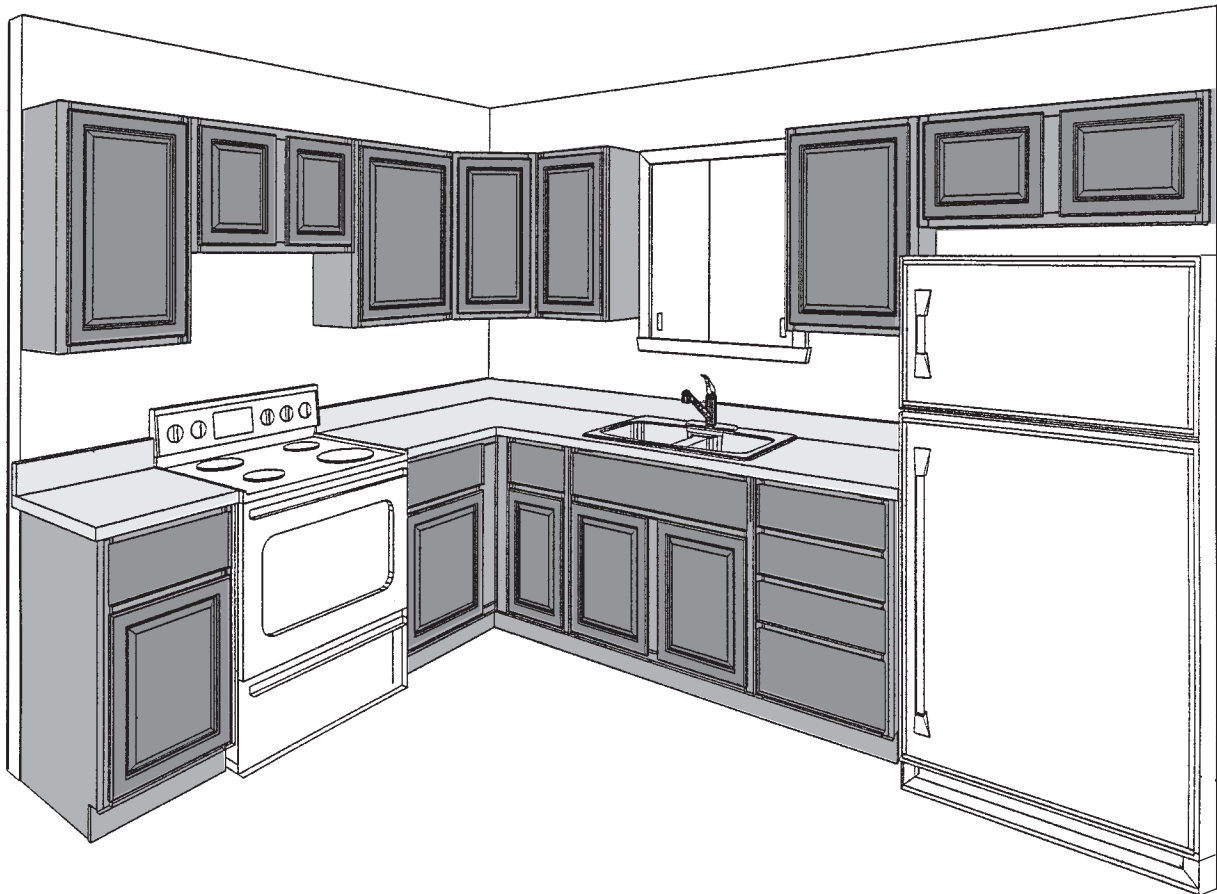

4.

Helpful Hints

- ✓ Be sure there is adequate access to remodeling areas.
- ✓ Reduce the spread of dust and dirt by covering all work area openings.
- ✓ Allow plenty of time for product delivery.
- ✓ Check all new cabinetry before tear down begins.
- ✓ Have plenty of room for opening uncartoned products.
- ✓ Plan for removing additional trash and debris.
- ✓ Make provisions for food preparation, utensils, and clean-up while your kitchen is being remodeled.

Echelon[™]
CABINETY

www.echeloncabinetry.com



Echelon Cabinetry is part of the Kitchen Cabinet Manufacturers Association (KCMA) and the National Kitchen and Bath Association (NKBA). Echelon Cabinetry carries the ANSI/KCMA A161.1 quality assurance certification.